



## TECHNICAL DATASHEET

### HEALTHCARE TAPWARE

#### Fixed or adjustable spout hospital mixer tap with pressure balancing cartridge - Modul'Mix - 75719



#### Benefits of the product

- Modul'Mix range: modularity of parts and adaptability to needs
- Retrofitable and customizable
- Elbow control lever: avoiding manual contact
- Comfortable height to spout and projection for washbasin
- Multifunctional pressure balancing cartridge: temperature limit stop with 7 adjustment positions, double flow (hard point at 50% opening).
- Pressure Balancing ceramic cartridge: "basic plus" anti-scalding safety via temperature limiter ring. **Strong restriction of the DHW flow rate in the event of a DCW cut-off, and vice versa**
- Flow between 10 and 15L / min at 3 bar. Included check valves.
- Fixed or adjustable spout (optional), removable with smooth interior: facilitates cleaning and disinfection, limits the deposit of the biofilm.
- Star-shaped flow straighteners: limits the water spray, no water retention.
- Simple and fast maintenance

#### Description

Single hole hospital mixer tap (modul'mix design) without drainage for handbasin, with long medical control Len 170mm to avoid hand contact, operated by elbow, forearm or wrist. Fixed or directional, smooth and removable for disinfection Len 250mm. Spout height 100mm. The spout height and length can be adapted without changing the complete tap. Ø 40 ceramic pressure balancing cartridge: temperature limiting stopper with 7 setting positions, dual flow (hard point at 50% opening). Flow between 10 and 15L / min at 3 bar. Integrated check valves. Standard star-shaped tap-nozzle which limits the risk of limescale, eliminates water retention and impurities and is resistant to chlorine and thermal shock treatments. Smooth body, spout and control component in polished chrome-plated brass. Hoses with SPEX sheath braided stainless steel M10X1, EP G'3/8, Len 500mm. Fixture strengthened using a stainless steel rod. 10 year guarantee. Sanifirst brand type single hole pressure balancing hospital mixer tap with removable fixed or directional smooth spout for handbasins REF: 75719 or approved equivalent.

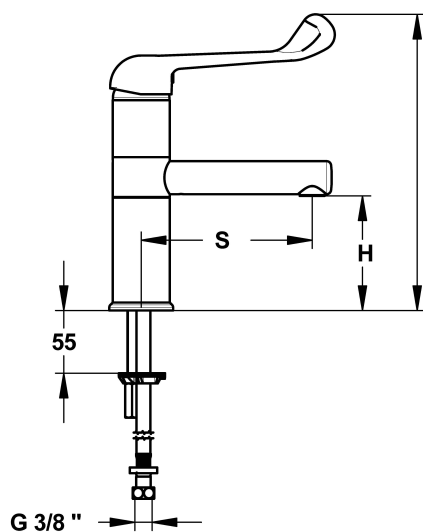



## TECHNICAL DATASHEET

### Additional Information

<b>Product reference</b>	75719
<b>Previous reference</b>	NC
<b>Brand</b>	Sanifirst
<b>Warranty</b>	10 years against any manufacturing defect
<b>Special feature 1</b>	Fixed spout
<b>Special feature 2</b>	Swivel spout
<b>Special feature 3</b>	Removable spout
<b>Height to nozzle (mm)</b>	100
<b>Projection (mm)</b>	250
<b>Length of lever (mm)</b>	170
<b>Clip-on spout</b>	No
<b>Flow straightener</b>	Star shaped flow straightener, M24 x 1
<b>Connection</b>	SPEX hoses 500 mm - M10 X 1 - LN G'3 / 8 with basket filter seals
<b>Minimum pressure</b>	1 bar
<b>Recommended pressure</b>	3 bar with a pressure differential less than 1 bar
<b>Maximum pressure</b>	5 bar
<b>Max tightening</b>	40
<b>Cartridge</b>	75313 Ø 40mm, double flow, temperature limiter, pressure balancing
<b>Coating</b>	Nickel > 10 microns - Chrome > 0.3 microns