

**Range:** SELF-SUPPORTING MOUNTING FRAME WITH DIRECT FLUSH VALVE

**Ref:** 18546 - Self-supporting mounting frame - PRESTO 1000 XL

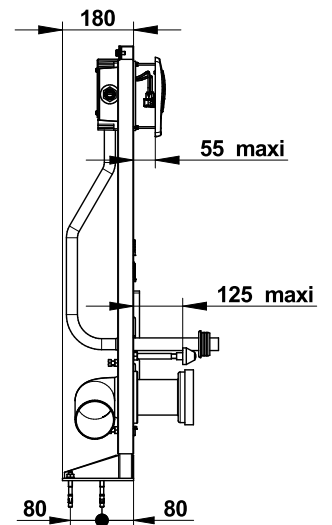
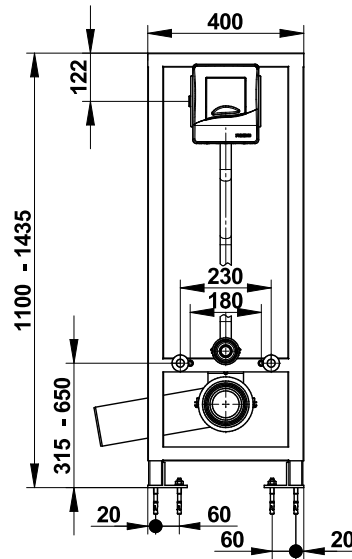

#### > Working pressure:

- 1 to 5 bar

#### > Volume of water delivered:

- Adjustable from 6 to 9 l
- Anti-water-hammering design
- Automatic 1 l/s flow limiter, 1.2 to 4 bar dynamic working pressure

#### > Hydraulic supply:

- On PRESTO 1000 XL con integrated stop valve M G 3/4" (20x27)
- Power supply on the right or the left side of the box

#### > Material and colour finish:

- 60 micron epoxy coated soldered steel mounting frame
- Galvanized legs and floor fixing plates
- Brass body flush valve
- Tilting white ivory front panel

#### > Security:

- Patented anti-blocking "S" system preventing the tap to be blocked in open position to avoid continued water flow
- Anti-siphonic device

#### > Delivered with:

- 1 Brass coupling nut Male Female 3/4" (20x27)
- 1 PVC angle tube Ø 32 mm and 1 junction nozzle male 55 mm
- 1 Extended straight PE tube 100 mm with adapter sleeve for connection to the bowl
- 1 WC outlet angle PVC pipe dia. 100 mm
- Screw and dowel for toilet bowl fixing

#### > Standards & approvals:

- Acoustic class II
- Brass body in accordance with EN 1982, EN 12164, EN 12165
- Molded chrome-plated body in accordance with EN 12540
- 200-hour neutral salt spray resistant (NSS) in accordance with ISO 9227

