

Range: PRESTO NOVA®

Ref: 55385 - Deck-mounted sensor mixer, 3l/min, battery, without stop valve

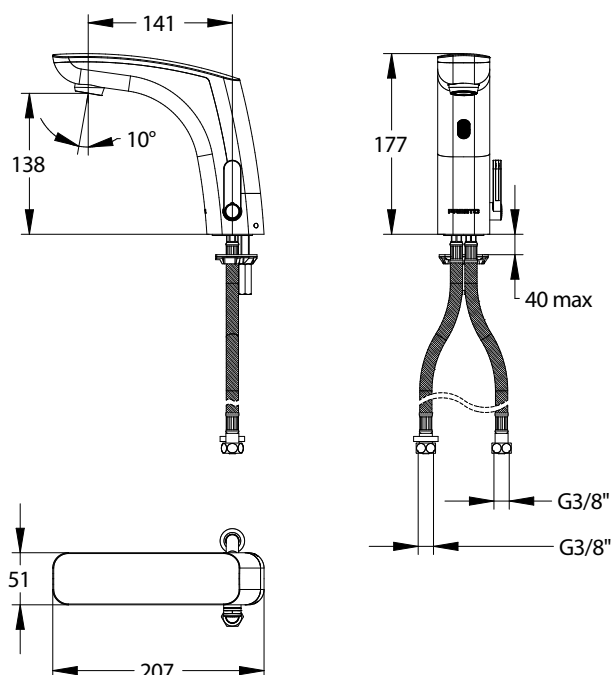

> Working pressure :

- 1 to 5 bar

> Function:

- Starts and stops automatically by hand detection
- Sensor trigger suitable for PRM, elderly, children and disabled people

> Flow:

- 3l/min at 3 bar with integrated regulated anti-limescale aerator

> Hydraulic supply:

- F G 3/8" (12x17) hoses

> Power supply :

- Integrated 6V CRP2 lithium battery in a waterproof case

> Material and colour finish :

- Injected molded metal body
- Chrome plated cover

> Thermal resistance :

- Resistant to a temperature of 75°C for 30 minute thermal shocks

> Security :

- Anti-overflow security time set to 30 seconds preventing the water to flow continuously
- Automatic shutdown of solenoid valve in case of low battery or sensor damage
- Duty flush 30 sec every 24h after last use (adjustable flow time and frequency with PRESTOCOM)
- Low battery alert (blinking led light)
- Maximum temperature limitation with adjustable temperature stop

> Delivered with :

- 1 Brass clamping nut
- 1 Gasket and 1 Washer
- 2 PEX Hoses with revolving nuts and NF check valves
- 2 Filter gaskets
- 1 Self-adhesive sticker
- Instruction manual

> Standards & approvals :

- Brass in accordance with EN1982, EN12164, EN12165
- 200-hour neutral salt spray resistant (NSS) in accordance with ISO 9227

