

Range: PRESTOTEM 2

Ref: 88832 - Shower panel with PRESTO TOUCH® tapware

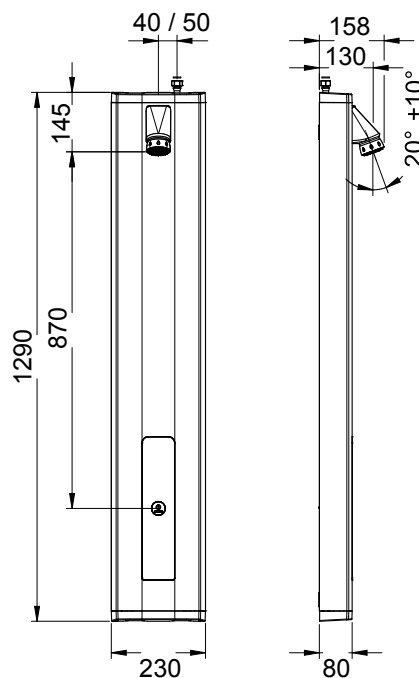

> Working pressure :

- 1 to 5 bar

> Flow rate:

- 6l/min with integrated flow limiter
- Anti-water-hammering device
- Fixed shower head with anti-limescale spikes

> Flow time:

- 30 seconds (adjustable from 1 sec to 5 min) and Start/Stop function
- Adjustable duration and frequency of the "duty flush" function

> Hydraulic supply :

- G 1/2" (15x21), top or rear water inlet. For rear water inlet, we recommend to add the adaptation kit under the reference 91026
- On the PRESTO TOUCH® tapware with cold or pre-mixed water

> Power supply:

- 6 V Lithium battery type CRP2 in a case integrated inside the panel

> Material :

- Anodised aluminium extruded section (2.5mm thickness)
- Aluminium removable valve plate, painted RAL 7005 colour
- High resistance RAL 7005 coloured ABS covers

> Functioning:

- Wide opening panel without the need to dismantle from the wall and shower taps on a removable valve plate

> Thermal resistance :

- Resistant to a temperature of 75°C for 30-minute-thermal-shocks

> Security :

- Possibility to parameter the periodical flushing in term of frequency or flow time
- The solenoid valve closes automatically if the battery runs out or the sensor is damaged

> Delivered with :

- 1/2" hoses with revolving nuts
- MM 1/2" (15x21) straight stop valves and 250 micron filters
- Fastening screws and instruction manual

> Standards & approvals :

- Brass body in accordance with EN 1982, EN 12164, EN 12165
- Chrome-plated surface treatment in accordance with EN 12540
- 200-hour neutral salt spray resistant (NSS) in accordance with ISO 9227

