

Range: Tube with junction nozzle

Ref: 55372 - TUBE FOR SIPHONIC URINAL - OPTION FOR SENSOR TAP

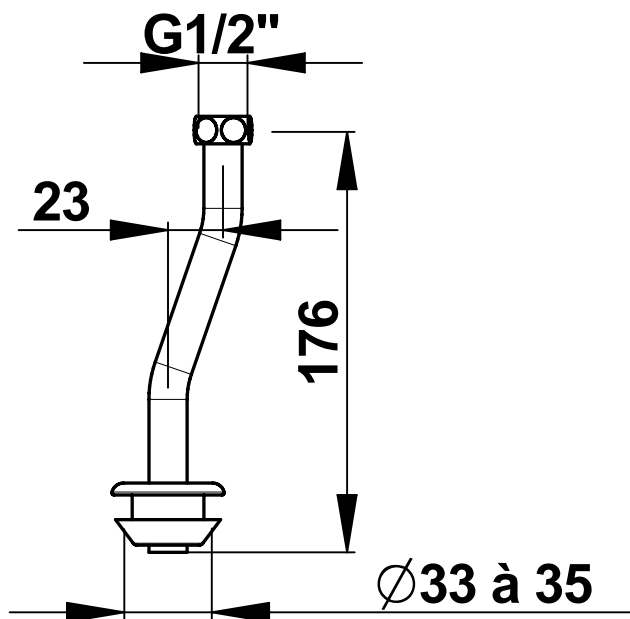

> Function :

- Exposed mounting tube allows water connection to siphonic urinal.

> Composition

- 1 chrome-plated copper tube

> Material and colour finish :

- Chrome-plated copper body
- Waterproof by the Nitrile/EPDM elastomer

> Standards & approvals :

- Brass body in accordance with EN 1982, EN 12164, EN 12165
- Chrome-plated body in accordance with EN 12540
- 200-hour neutral salt spray resistant (NSS) in accordance with ISO 9227

> Guarantee :

- 10 years (see the general sales condition)