

Range: PRESTO CHEF - Professionnal Kitchen range
Ref: 70808 - Deck-mounted mixer tap with 2 holes – upward spout

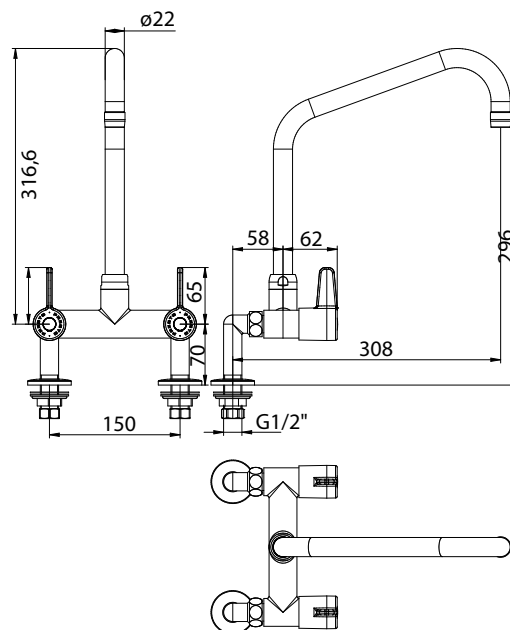

> THE PRODUCT BENEFITS

- Resistant to intensive use
- Reinforced body / spout interface with double sliding bearings: no play and high endurance
- Robust spout: diameter 22 mm
- Intuitive and ergonomic knobs: easy grip
- Hygiene: spout with smooth interior
- Product design
- Ease of cleaning
- Easy maintenance: presence of a slot under the red / blue patch allowing the passage of a screwdriver
- Ease of maintenance: availability of all spare parts
- Flow straightener to channel water and avoid lateral water splashes

> TECHNICAL SPECIFICATIONS

> Model:

- Two-hole deck mixer with spout above
- 360° swivel spout, projection 308 mm, height under spout 296 mm, diameter 22 mm. Spout thickness: 1.5 mm.
- 1/4 turn ceramic head
- Interchangeable anti-tartar flow straightener

> Recommended working pressure:

- 1 to 5 bars

> Flow rate:

- 81L / min at 3 bar

> Hydraulic supply:

- G 1/2" (15x 21)

> Material and color of finish:

- Chromed brass body and spout
- Material compliant with the "UBA" list

> Thermal resistance :

- Withstands a temperature of 75 ° C for 30 minutes (in the context of thermal shock).

> Delivered with:

- Columns with nut
- 2 filters

> Standards and approvals:

- Chromed brass body compliant with standards NF EN1982 / NF EN 12164 / NF EN 12165
- Nickel-Chrome surface treatment according to NF EN12540
- Resistance to neutral salt spray (NSS): 200 h according to NF ISO 9227