

**Range :** Deck-mounted mixer tap

**Ref :** 20520 - PRESTOMIX 2020 S, anti-blocking 'S' system

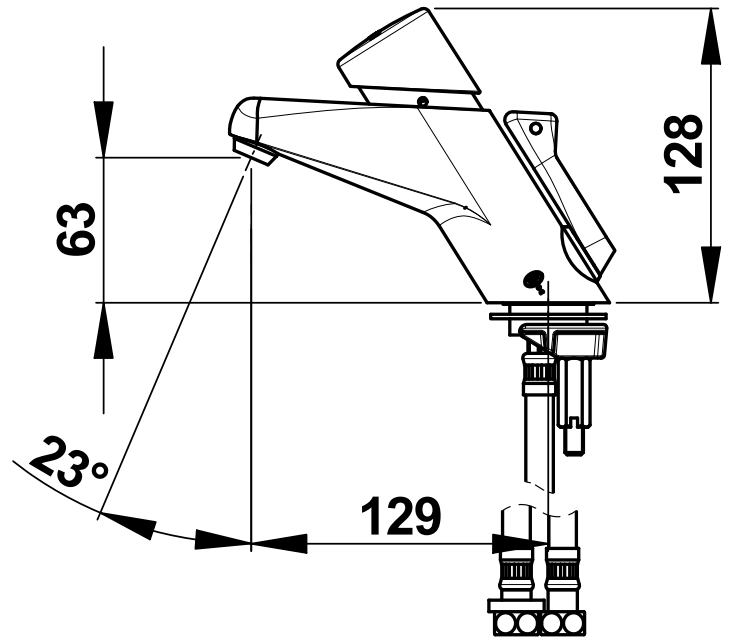

**> Working pressure :**

- 1 to 5 bar

**> Flow :**

- 5 l/min Flow limiter - 5-position flow adjustment device
- Anti-water-hammering design
- Vandalism proof and anti-clogging spout

**> Flow time :**

- 15 seconds ( ± 5 sec.) - adjustable 4-position

**> Hydraulic supply :**

- G 3/8" (12x17)

**> Thermal resistance :**

- Resistant to a temperature of 75°C for 30-minute-thermal-shocks

**> Security :**

- Adjustable tamper-proof temperature limiter to prevent scalding
- Patented anti-blocking "S" system to avoid the water to flow continuously

**> Delivered with :**

- 2 Filter gaskets
- 2 PEX hoses with NF check valves and nuts
- Fixing bracket
- 1 Flange gasket
- 1 Brass clamping nut
- Instruction manual

**> Standards & approvals :**

- Brass body in accordance with EN 1982, EN 12164, EN 12165
- Chrome-plated surface treatment in accordance with EN 12540
- 200-hour neutral salt spray resistant (NSS) in accordance with ISO 9227

