

Range: Modular detection for urinal

Ref: 52464 - Extra-flat detection

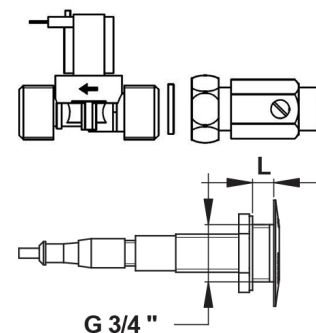
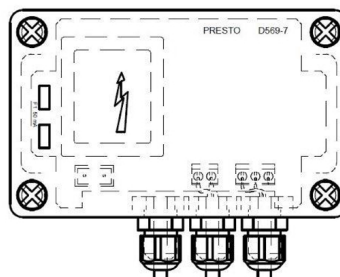

> Application:

- For urinal: induct mounting (for partition from 10 to 50mm)

> Working pressure:

- 1 to 5 bar

> Flow:

- 10 l/min with flow limiter
- Anti-water-hammering design

> Flow time:

- 7 seconds (± 1s)
- Adjustable from 3 to 16 seconds

> Range:

- Preset to 600 mm
- Range adjustable from 100 to 700 mm

> Hydraulic supply:

- On G 3/4" solenoid valve - Cold or mixed water

> Power supply:

- 230 V / 12V - 6VA Transformer (IP65 casing) included

> Thermal resistance:

- Resistant to a temperature of 75°C for 30-minute-thermal-shocks

> Delivered with:

- 1 IP65 detection cell - For partitions 1 to 50 mm thick and 2m of cable
- 1 G 3/4" solenoid valve
- 1 Stop valve
- Transformer (IP65 casing)
- Instruction manual

> Standards & approvals:

- Molded chrome-plated body in accordance with EN 12540
- 200-hour neutral salt spray resistant (NSS) in accordance with ISO 9227
- Security transformer in accordance with EN 60 742

