

**Range:** PRESTO Slim

**Ref:** 52700 - SLIM deck-mounted soap dispenser, mains powered.

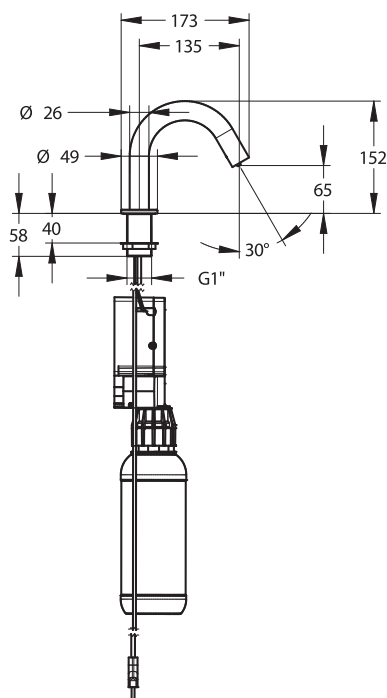

#### Operation:

- Automatic activation and shut-off by presence detection.
- Suitable for PRMs, the elderly and children.

#### Delivered volume:

- 0.5ml.

#### Capacity:

- 1L reservoir bottle attached to housing.
- Easy refilling by unclipping bottle.
- Easy filling with wide neck.

#### Compatible products:

- Suitable for liquid soap.
- Liquid soap viscosity: 100 - 3000 mPa.s.

#### Main material and finish:

- Technical polymer housing.
- Stainless steel tube and base plate.
- Brass clamping screw.
- Chrome finish.

#### Power supply:

- Mains 230V plug-in to wall socket.

#### Recommended installation:

- Housing to be installed in an accessible location for easy bottle filling.
- Soap reservoir can be offset for liquid soap applications with extension kit not supplied.
- The electric soap dispenser is compatible with vegetable-based liquid soap with a PH between 5 and 9, with a maximum viscosity of 3000mPa.s. Our mechanisms do not work with hydroalcoholic solutions or with soaps for industrial use or containing microbeads.

#### Delivered with:

- 1L reservoir bottle.
- Plug-in transformer.