

Range: Grab bars and support rail

Ref: 60529AV - 135° Angled rail - Diameter 32mm - With virucidal film

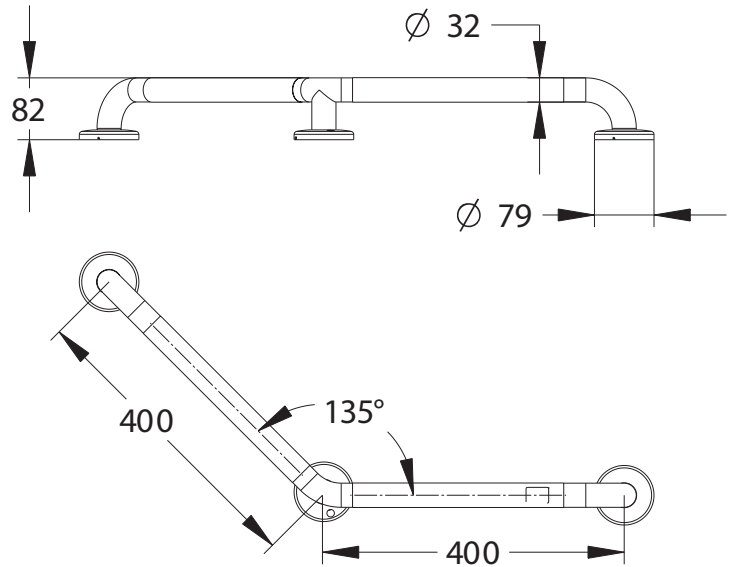

> The product benefits

- Adapted to mobility-reduced people
- With a transparent **COVERSAFE™** virucidal film with many advantages:
 - 1 hour: destruction of 96% of the **CORONAVIRUS SARS-CoV-2** (responsible for COVID-19)
 - 24h: destruction of 99.9% of viruses and bacteria *
 - 4 years: efficiency tested and validated
- **PYLOTE** natural technology: safe use, harmless to the skin. Tested and validated by certified laboratories.
- Discreet: transparent film, matt finish, removal without residue (if necessary), and possibility to replace the film
- Easy maintenance: compatible with usual cleaning products (soap, gel, disinfectant). Without degradation of antimicrobial activity, continuous effectiveness

> Dimensions:

- Diameter: 32 mm
- Length: 400 x 400 mm
- 3 anchor points

> Material and finish color:

- Steel tube
- Screwed fixing plates
- RAL 9003 white epoxy paint finish
- The bar is covered with a transparent **COVERSAFE™** virucidal film: continuous triple protection (viruses, bacteria and germs)

> Delivered with:

- Steel clip-on rosettes for concealing fixing screws

> Standards / Approvals:

- 200-hour neutral salt spray resistant (NSS) in accordance with ISO 9227

> * Tests performed according to **JIS Z 2801, ISO 22196 and ISO 21702 standards by independent and accredited laboratories.**