

Range: Modul'mix

Ref: 74074 - MODUL'MIX SAFE+ hospital Thermostatic Mixer Tap fixed or swivel spout h100 p150

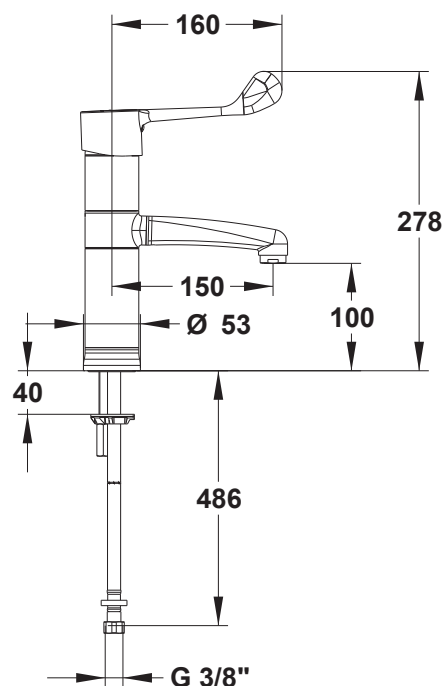

## The "plus" products

- Modul'Mix range: modularity of parts and adaptability to needs
- Retrofittable and customizable: different spout lengths and different extensions to adapt the height to spout
- Ergonomics: elbow operated lever (for patients and technical staff)
- Hand hygiene: avoids manual contact
- Comfortable spout heights and projections for washbasin cleansing
- Adjustable temperature limiter
- Fixed or swivel spout (choice), removable with smooth interior: facilitates cleaning and disinfection, limits biofilm deposition.
- Quick and easy maintenance
- Secure unlocking for thermal shock and accessible only by technical services.

## Model

- Single-hole hospital single-lever mixer on range, without drain
- Single-lever thermostatic cartridge : adjustable temperature limiter
- Ergonomic, elbow control
- Low water content spout
- Fixed or swivel spout, technician's choice
- Star jetbreaker limits the risk of scaling, retention, impurities and resists thermal shock
- Suitable for PMR, EHPAD, CH

## Dimensions

- Projection: 150 mm
- Height to spout: 100 mm

## Safety

- Anti-scald: control with adjustable temperature limiter.
- Anti-bacterial proliferation: impossible intercommunication between EFS and ECS, eliminating the need for check valves on the mixer's EFS and ECS inlets, created by the cartridge's ceramic discs.

## Flow rate

- Adjustable flow rate: 6L/min maximum at 3 bar
- Flow rate can be modified by removing the regulator.

## Materials

- Smooth body and polished chrome-plated spout.
- Brass base

## Fittings

- Hoses with stainless steel braided SPEX sheath M10X1, G'3/8 nut, Lg 486mm, with basket filter seal mounted in hoses, limiting clogging.
- Fixing reinforced by stainless steel rod

## Warranty:

- 10 years against any manufacturing defect.