

Range: Hoptim'

Ref: 75916 - HOPTIM' - Washbasin mixer C3 h 100 mm p 108 mm - solid lever - without waste

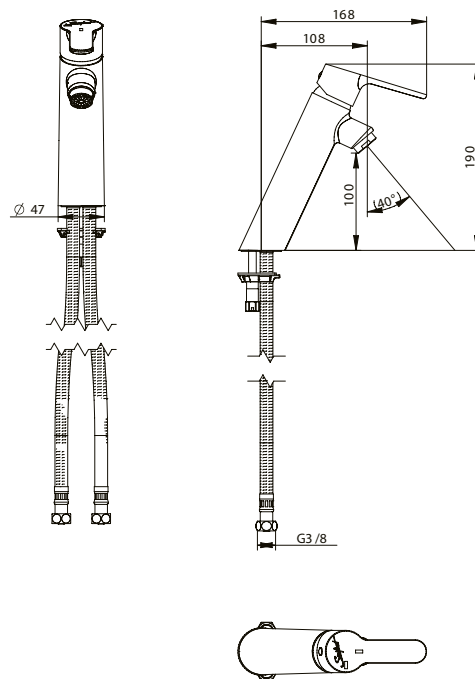

Benefits of the product

 Energy saving: opening on cold water

- Comfortable height to nozzle and projection: compliant with the French Medical NF norm
- Body inside and outside smooth: limiting the fixation of the biofilm and the proliferation of bacteria
- Solid lever: facilitates cleaning
- Modern design
- Very low water retention after the closure member

Ce document n'est pas contractuel ; nous nous réservons le droit de modifier les caractéristiques de nos produits sans préavis. Toutes nos marques et tous modèles sont déposés.

